

Amarillo®

DOUBLE REDUCTION FAN DRIVES

INSTRUCTIONS FOR REPAIRING

Amarillo Double Reduction Fan Drives, if properly installed and maintained, should provide years of service with a minimum amount of maintenance. Repairs, when required, usually involve bearing or gear replacement. While the job is not difficult, it should only be performed in an adequately equipped shop by capable personnel. It should be noted that any repairs made outside the factory on new drives without the consent of the manufacturer will void the warranty.



MEMBER

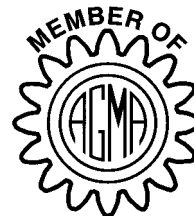

Catalog DRR 5/02

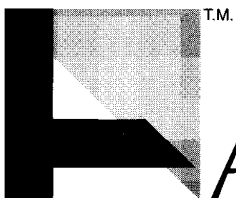

Amarillo® Gear Company

Post Office Box 1789 • Amarillo, Texas 79105 • 2401 Sundown Lane (79118) 806-622-1273 • FAX 806-622-3258

www.amarillogear.com

email: info@amarillogear.com

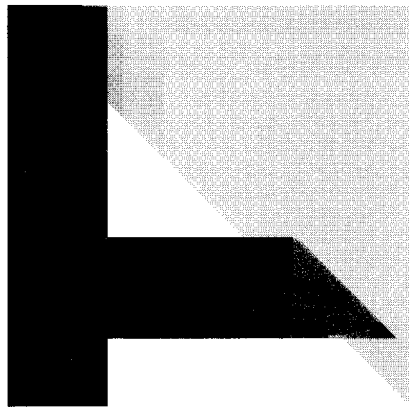

Amarillo[®]
Gear
Company

T.M.

- ATTENTION -

Please note that gear drives with a serial number above 231989 have all joints sealed with Loctite Gasket Eliminator 515 instead of gaskets. Loctite 515 is a formed in place gasket material, which provides superior sealing over conventional gaskets. After disassembly for repair or inspection, we recommend resealing with Loctite 515. However, gaskets may still be used. If a gasket is utilized between the horizontal carrier and the gear case for a gear drive originally built with Loctite, the flange thickness of bearing bushing (20) or hardened washer (201), if applicable, will have to be changed to maintain the proper position of the horizontal gear. To correct the horizontal gear position, increase the horizontal spacer thickness by the thickness of the gasket. If Loctite is used to re-seal the gear drive then no changes are required to the horizontal spacer.

TABLE OF CONTENTS

	Page
1.0. General Disassembly Instructions	1
2.0. Disassembly of Input Shaft Assembly	5
2.2. Models 1008 and 1110	5
2.3. Models 1311, 1712, and 1713	8
3.0. Disassembly of Intermediate Shaft Assembly	8
4.0. Disassembly of Output Shaft Assembly	8
5.0. General Assembly Instructions	10
6.0. Assembly of Output Shaft Assembly	10
7.0. Assembly of Intermediate Shaft Assembly	10
8.0. Assembly of Input Shaft Assembly	11
8.2. Models 1008 and 1110	11
8.3. Models 1311, 1712 and 1713	12
9.0. Installation of Assemblies into Gear Case	13
10.0. Adjustment of the Input Shaft Bearings	13
11.0. Backlash Check	13
12.0. Spiral Bevel Tooth Contact Pattern Check	16
13.0. Adjustment of the Intermediate Shaft Bearings	16
14.0. Adjustment of the Output Shaft Bearings	16
15.0. Completion of Assembly	17
16.0. Disassembly of the Oil Pump	17
17.0. Assembly of the Oil Pump	17
18.0. Disassembly of the Input Stem Pinion Assembly	19
19.0. Assembly of the Input Stem Pinion Assembly	19
20.0. Installation of New Gear Mount	20
21.0. Spiral Bevel Tooth Contact Pattern and Adjustment	21
22.0. Spiral Bevel Backlash Adjustment	21
23.0. Shaft Seals	24
Tables:	
1. Center Distance	1
2. Lift Point	1
3. "C" Values	15
Figures:	
1 Models 1008 and 1110	2
2 Models 1311, 1712 and 1713	3
3 Strong Back	4
4 1008 Horizontal Assembly	6
5 1110 Horizontal Assembly	7
6 Horizontal Assembly Without Gear Retainer	7
7 Horizontal Assembly With Inner Spacer	9
8 Horizontal Stem Pinion Assembly	9
9 Backlash Check	14
10 Oil Pump Assembly	18
11 Horizontal Stem Pinion Assembly	19
12 New Gear Mount	20
13 Correct Tooth Contact Pattern	22
14 Profile Error	22
15 Cross Contact	23
16 Shaft Angle Error	23
17 Input Shaft Seals	24
18 Output Shaft Seals	24

1.0. General Disassembly Instructions

- 1.1. Refer to the appropriate cross sectional drawing during disassembly. See Fig. 1 or Fig. 2.
- 1.2. Drain and dispose of oil.
- 1.3. Remove the side and upper (18) inspection plates.
- 1.4. Remove the upper seal plate (11) by removing the three set screws.
- 1.5. Match mark the vertical seal carrier (21) and the vertical cover (12). Remove the vertical seal carrier (21), taking care not to damage the shim pack (located underneath the seal carrier).
- 1.6. Match mark the upper intermediate bearing cover (19) and the vertical cover (12). Remove the upper intermediate bearing cover (19), taking care not to damage the shim pack (located underneath the intermediate bearing cover).
- 1.7. **Be sure not to interchange the shim packs.**
- 1.8. Remove the horizontal oil seal plate (16). Remove the seals (802) from the seal plate and discard.
- 1.9. If the unit is equipped with an oil pump, an oil line will have to be removed before the vertical cover is removed.
 - 1.9.1. Positioned to the left and just inside the side inspection opening is the oil line distribution block. Locate the 3/8" oil line that is connected to the vertical cover.
 - 1.9.2. Disconnect the line from the distribution block.
- 1.10. Remove the bolts and tapered pins holding the vertical cover (12) to the gear case (10).
- 1.11. Thread two eye bolts into the bolt holes for the upper seal carrier (21) and the upper intermediate bearing cover (19). Remove the vertical cover (12) with a hoist.
- 1.12. Remove the upper output and intermediate bearing cups (600 and 604) from the vertical cover (12).
- 1.13. **Note** the position of any oil lines (if applicable) that have to be removed as they will have to be reassembled in the same position.
- 1.14. The vertical output shaft and intermediate shaft assemblies must be lifted out of the gear case (10) at the same time, to prevent damage to lower bearings (601 and 605) and the helical gears (200). This will require the use of a strong back. The strong back must be of sufficient length to extend across both shafts. See Fig. 3. The center distances between the shafts are listed in Table 1.

MODEL	CENTER DISTANCE
1008	8 INCHES
1110	10 INCHES
1311	11 INCHES
1712	12¼ INCHES
1713	13¾ INCHES

TABLE 1

- 1.15. Attach the strong back to the top of the output shaft (400) with a 3/4-10 NC bolt. A piece of 1/2-13 NC allthread is required to extend through the strong back and thread into the end of the intermediate shaft (200). A nut should be placed on each side of the strong back and threaded up tight.
- 1.16. The two shaft assemblies should be picked up with a hoist located above their common center of gravity. Locate the dimension for the lifting point in Table 2.

MODEL	--- X --- DISTANCE FROM OUTPUT SHAFT CENTER LINE
1008	1¾ INCHES
1110	2 INCHES
1311	2¼ INCHES
1712	2½ INCHES
1713	2¾ INCHES

TABLE 2

- 1.17. Lift the assemblies out of the gear case (10). **CAUTION:** Make sure the lower intermediate bearing (605) clears the gear retainer (561) or inner bearing retainer (561), whichever is applicable. **CAUTION:** Take care not to damage the roller cages of the lower bearing cones (601 and 605) when setting the shaft assemblies on the work surface.
 - 1.17.1. If the unit is equipped with an oil pump, remove the oil pump drive plate (303) before setting the shaft assemblies on the work surface.

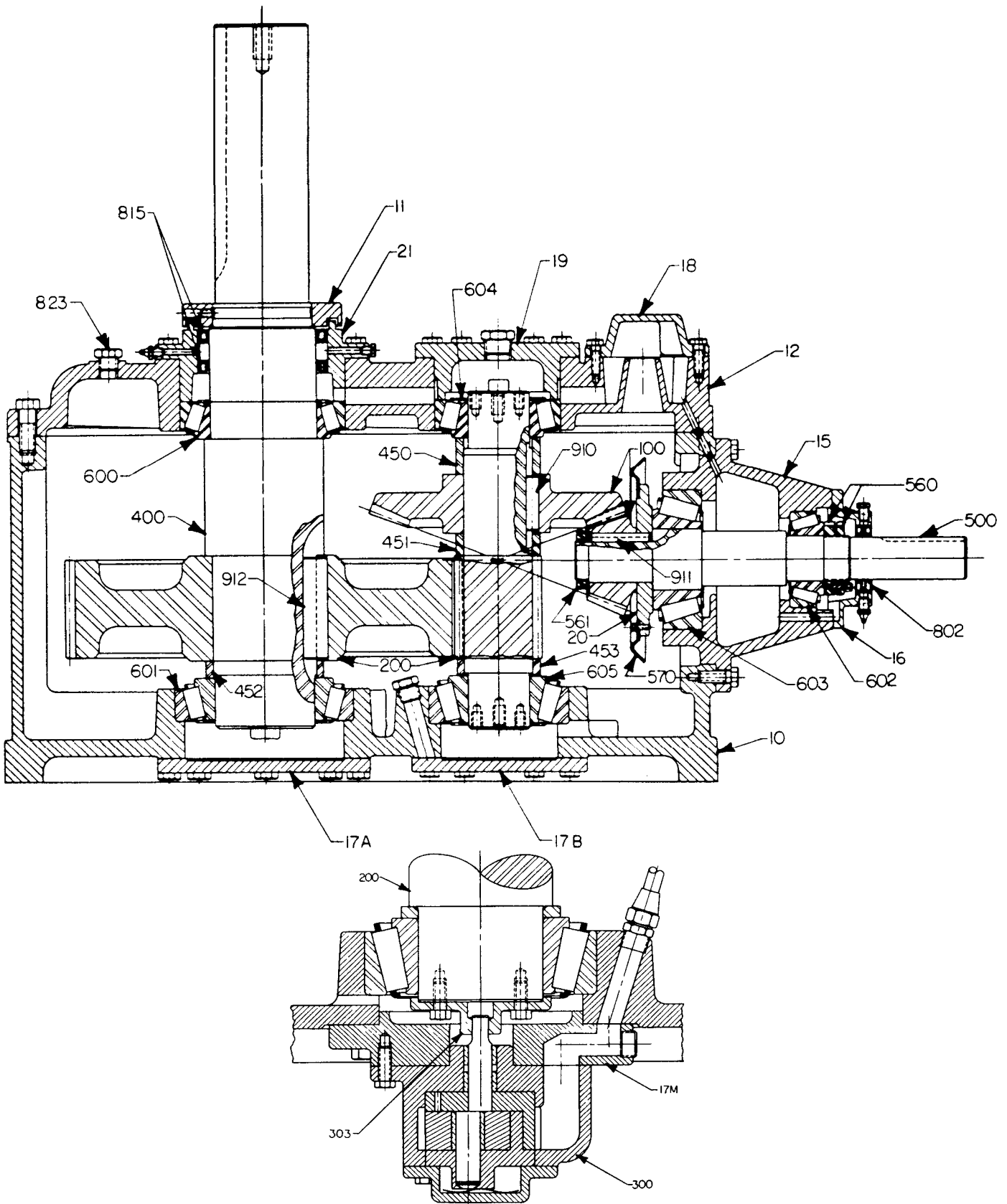

OPTIONAL OIL PUMP
MODEL 1008 & 1110
FIGURE 1

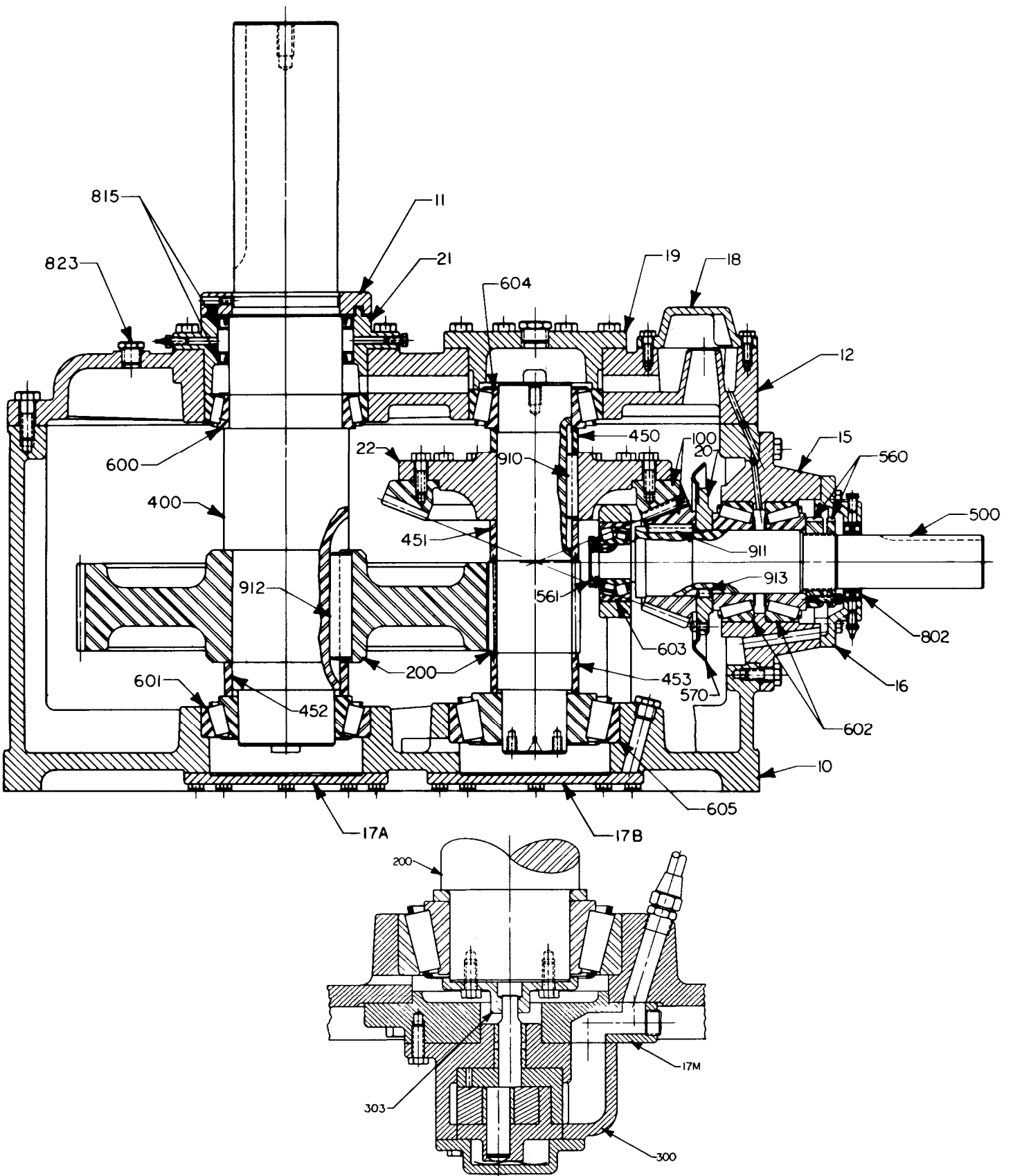

OPTIONAL OIL PUMP
MODEL 1311, 1712 & 1713
FIGURE 2

- 1.18. Match mark the horizontal shaft carrier (15) and the gear case (10). Remove the horizontal shaft carrier (15) (Guide pins may be installed into the bolt holes, to help guide the carrier out of the gear case). A quick jerk up and down on the end of the input shaft (500) will usually pull the carrier out of the register in the gear case. If this is not sufficient to remove the carrier, a sharp blow **with a soft mallet** against the side of the shaft (500) will start the carrier moving and then it can be pried out of the register with two screwdrivers.
- 1.19. Tip the unit back so that the input shaft opening is pointing up.
- 1.20. Remove the lower output bearing cover (17A).
- 1.21. If the unit is equipped with an oil pump (300), proceed to step 16.0. If not, then remove the lower intermediate bearing cover (17B).
- 1.22. Remove the lower output and intermediate bearing cups (601 and 605), using a brass punch or bearing puller.
- 1.23. Place the unit back down on its base.
- 1.24. Thoroughly clean the inside of the gear case (10) and all parts with solvent. Make sure that all the oil lines (if supplied) and oil cavities are clear.

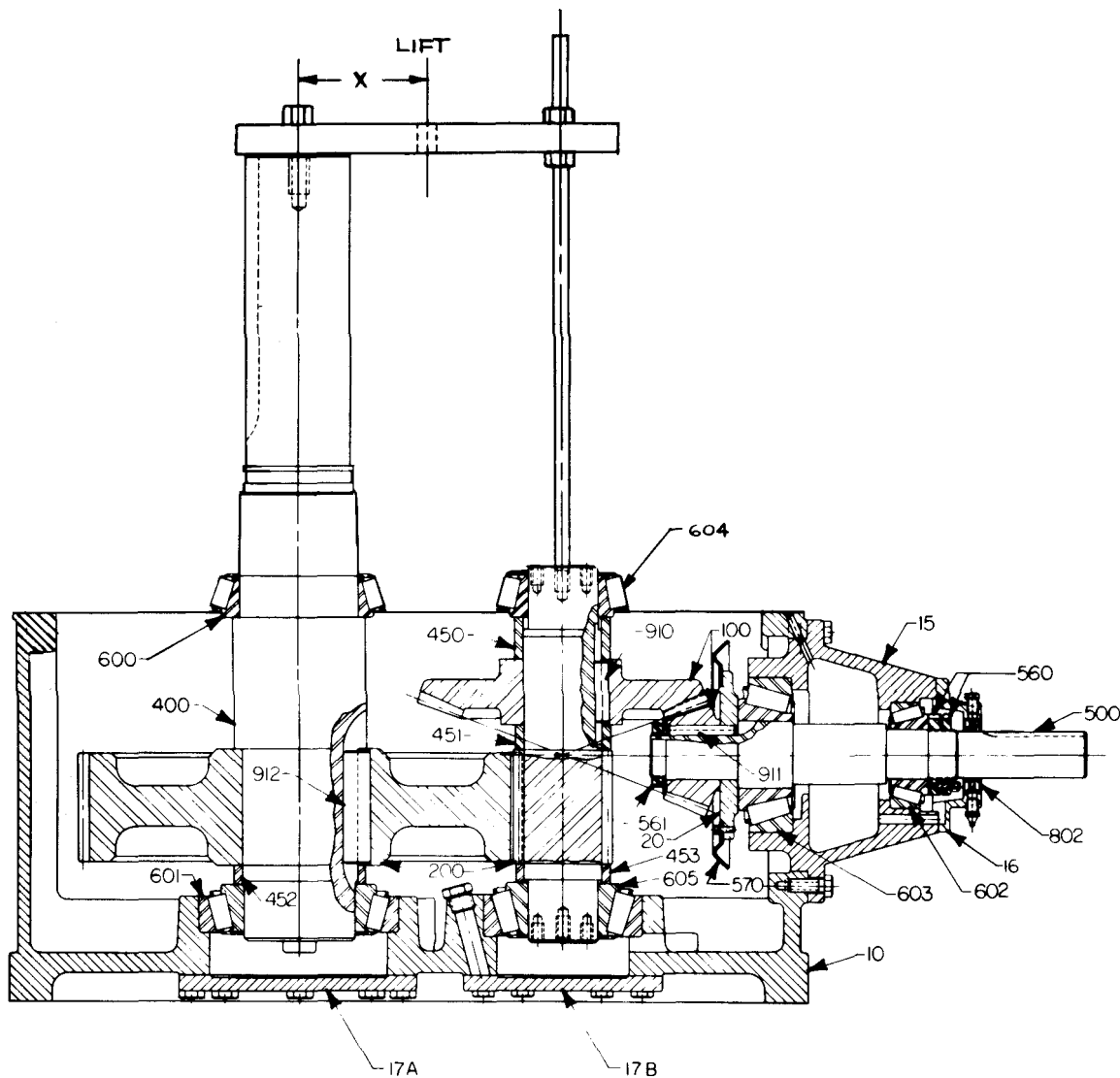

STRONG BACK
FIGURE 3

2.0. Disassembly of the Input Shaft Assembly.

- 2.1. Before disassembly, make a note as to which direction the oil slinger (570) is positioned. It must be reassembled in the same position in order to achieve proper lubrication.
- 2.2. Disassembly of the input shaft assembly for the models 1008 and 1110.
 - 2.2.1. Two types of input shaft assemblies are used on these models. One type requires the use of a horizontal gear retainer (561). The other type does not. See Fig. 4, Fig. 5 or Fig. 6.
 - 2.2.2. If the unit being repaired uses the horizontal gear retainer (561) proceed to the next step. If not, proceed to step 2.2.6.
 - 2.2.3. Place the input shaft assembly in a press so that the spiral bevel pinion (100) points up. **Note** the ram on the press must have an outside diameter that is smaller than the inside diameter of the horizontal gear retainer (561).
 - 2.2.4. After applying a light amount of pressure to the shaft, use a small drift punch or cold chisel to bend back the ears of the lockwasher that are down in the notches of the gear retainer, so that the nut can be turned. Pressure is applied to the shaft to hold it in place while the gear retainer is removed.
 - 2.2.5. Remove the gear retainer (561) using a drift punch or a spanner wrench (right hand threads).
 - 2.2.6. Turn the input shaft assembly over, so that the shaft extension points up. Place blocks underneath the shaft carrier (15) so that there is room to press the shaft downward.
 - 2.2.7. *Remove the socket head cap screws from the locknut set (560).*
 - 2.2.8. Remove the locknut set (560) using a drift punch or spanner wrench. Remove the thinner portion of the set first (right hand threads).
 - 2.2.9. Press the input shaft (500) down through the outer bearing (602). **Do Not** let the shaft assembly fall through and damage the threads on the end of the shaft.
 - 2.2.10. If the input shaft (500) uses a horizontal gear retainer (561) proceed to the next step. If not, proceed to step 2.2.14.
 - 2.2.11. Reposition the assembly in the press using a tube machined so the inside diameter will clear the outside diameter of the shaft and the outside diameter will fit inside the inner bearing cage (603). **Do Not** let the roller bearing cage rest on the tube.
 - 2.2.12. Press the shaft down through the spiral bevel pinion (100), oil slinger plate (20) and inner bearing (603).
 - 2.2.13. Proceed to step 2.2.17.
 - 2.2.14. Position the horizontal assembly in the press so that the pinion is resting on a tube. The tube must have an inside diameter which will clear the shoulder on the shaft (500) and an outside diameter which will fit inside the root of the pinion teeth.
 - 2.2.15. Press the shaft down through the inner bearing (603), oil slinger plate (20) and spiral bevel pinion (100).
 - 2.2.16. **NOTE:** Some ratios require a horizontal inner spacer (550). Do not lose this spacer, as it will be required during assembly.
 - 2.2.17. Remove the bearing cups, inner (603) and outer (602), from the horizontal carrier (15) using a brass punch or a bearing puller.
 - 2.2.18. Proceed to step 2.4.

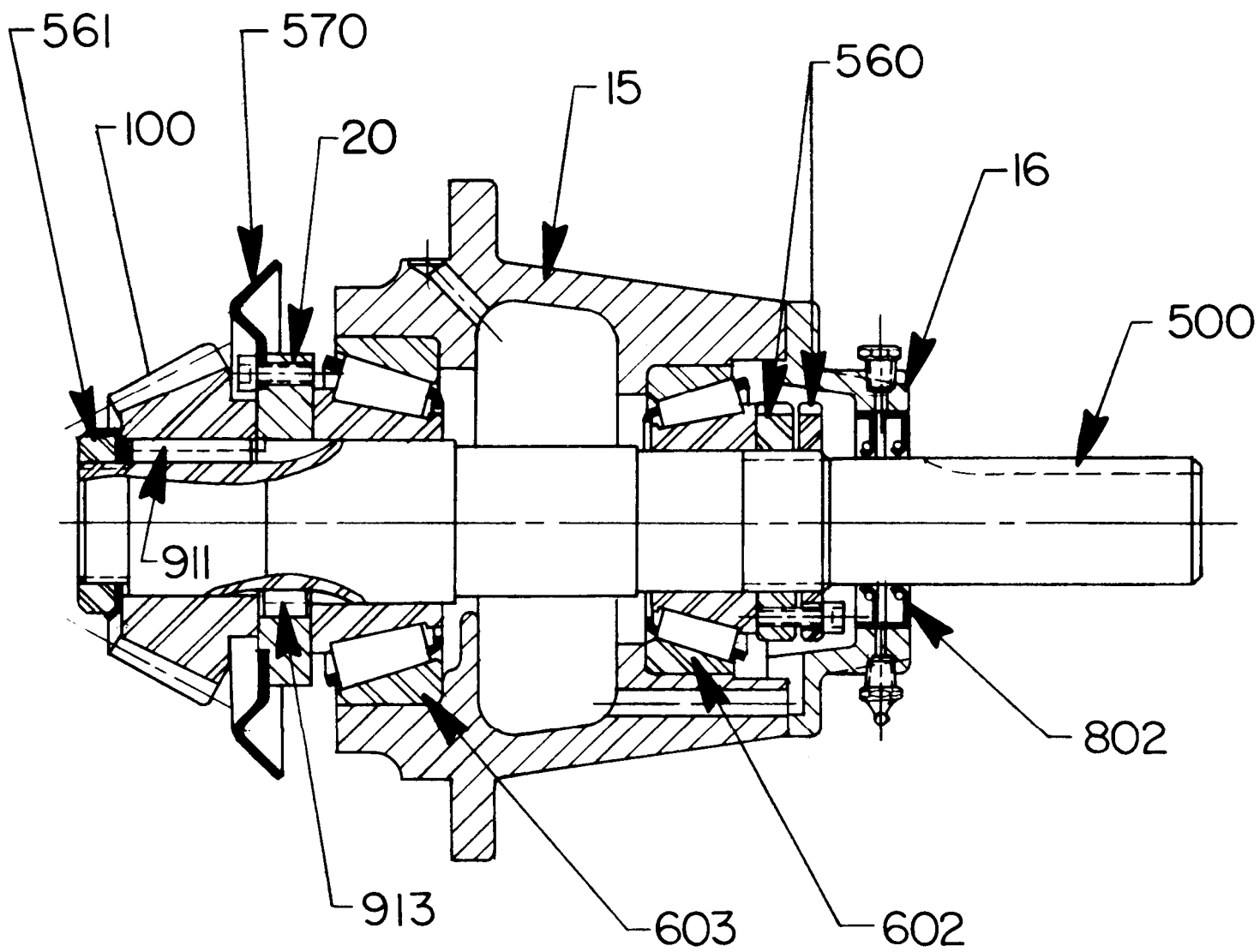

MODEL 1008

FIGURE 4

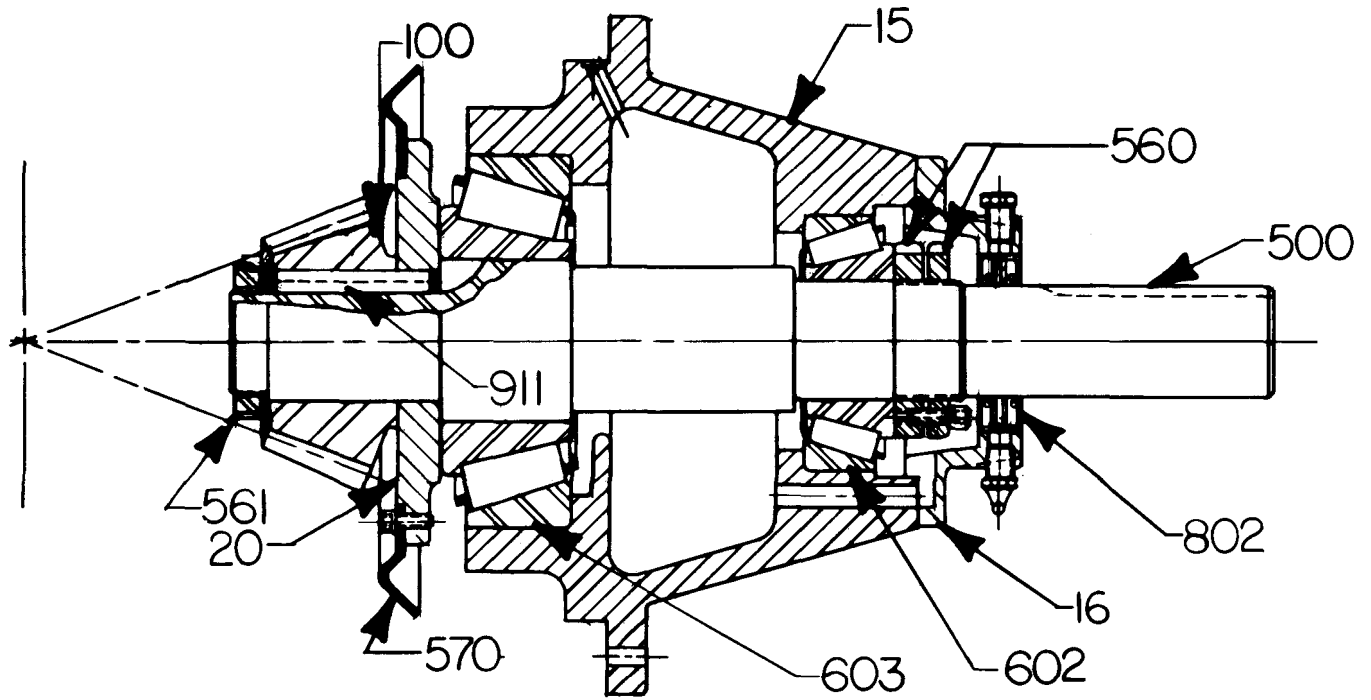

MODEL 1110
HORIZONTAL ASSB'Y

FIGURE 5

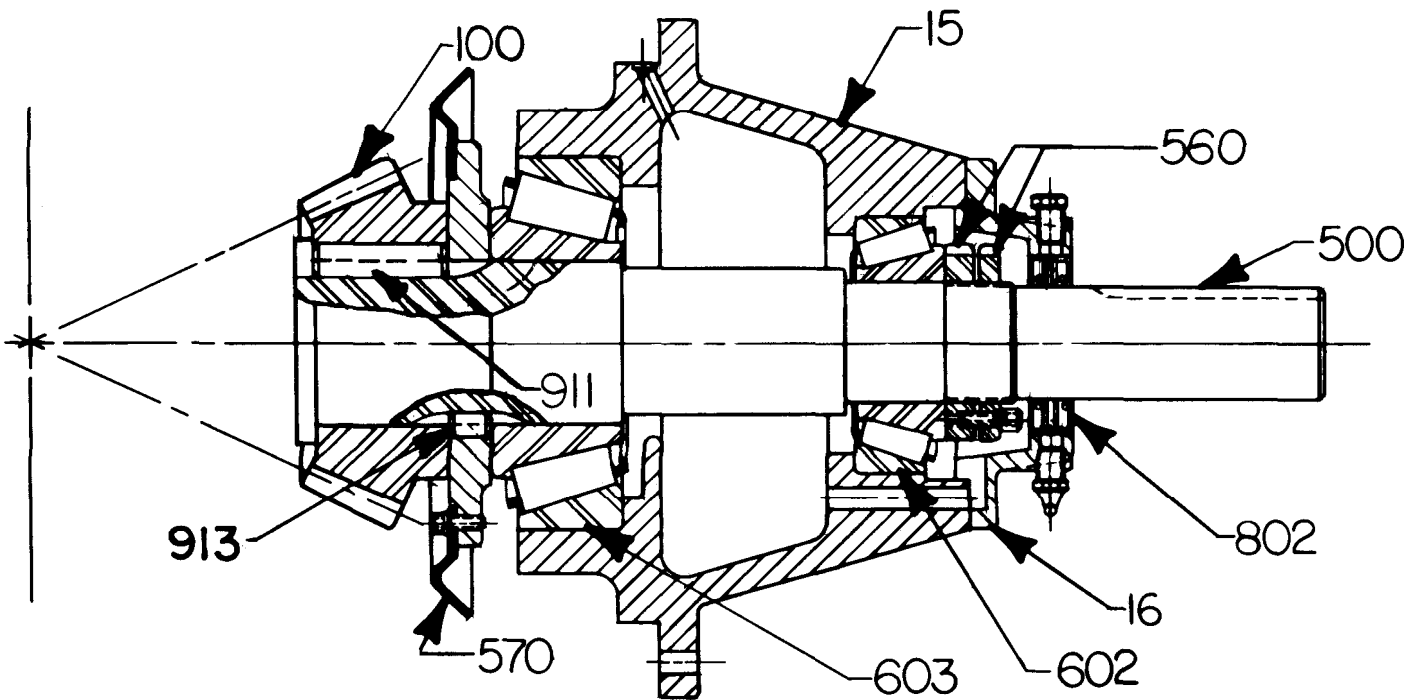

MODEL 1008 & 1110
HORIZONTAL ASSB'Y
WITHOUT GEAR RETAINER

FIGURE 6

- 2.3. Disassembly of the input shaft assembly for the models 1311, 1712 and 1713.
 - 2.3.1. There are three styles of input shaft assemblies. One is with the inner spacer (550) made as an integral part of the shaft, one is with the inner spacer made as a separate piece and the third is with the spacer and the spiral bevel pinion made as integral parts of the shaft (stem pinion). See Fig. 7 or Fig. 8. If both the spacer and the spiral bevel pinion are integral parts of the shaft, proceed to step 2.3.5.
 - 2.3.2. Place the input shaft assembly in a press so that the spiral bevel pinion (100) points up. **Note** the ram on the press must have an outside diameter that is smaller than the inside diameter of the horizontal bearing retainer (561).
 - 2.3.3. After applying a light amount of pressure to the shaft, use a small drift punch or cold chisel to bend back the ears of the lockwasher that are down in the notches of the bearing retainer, so that the nut can be turned. Pressure is applied to the shaft to hold it in place while the gear retainer is removed.
 - 2.3.4. Remove the bearing retainer (561) using a drift punch or a spanner wrench (right hand threads).
 - 2.3.5. Turn the input shaft assembly over, so that the shaft extension points up. Place blocks underneath the shaft carrier (15) so that there is room to press the shaft downward.
 - 2.3.6. Remove the socket head cap screws from the locknut set (560).
 - 2.3.7. Remove the locknut set (560) using a drift punch or spanner wrench. Remove the thinner portion of the set first (right hand threads).
 - 2.3.8. Press the input shaft (500) down through the outer bearing (602). **Do Not** let the shaft assembly fall through and damage the threads on the end of the shaft.
 - 2.3.9. If the unit uses a stem pinion, proceed to step 18.0. If the inner spacer is a separate piece proceed to step 2.3.15.
 - 2.3.10. Place the assembly in the press with the inner bearing (603) pointing up. Support the inner bearing with two square bars resting on a tube of sufficient length to hold the assembly above the table of the press. The Aube should have an inside diameter that will allow the assembly to fit inside.
 - 2.3.11. Press the inner bearing (603) off the shaft (500).
 - 2.3.12. Reposition the shaft so that the pinion is supported by the square bars or a piece of tubing that has an inside diameter larger than the outside diameter of the inner spacer (550). The outer bearing (602) and oil slinger plate (20) should be on top of the spiral bevel pinion (100).
 - 2.3.13. Press the shaft (500) down through the outer bearing (602), the oil slinger plate (20) and the spiral bevel pinion (100).
 - 2.3.14. Proceed to step 2.3.17.
 - 2.3.15. Reposition the assembly in the press so that the spiral bevel pinion (100) and the inner bearing (603) are pointing up. Support the assembly with a tube that has an inside diameter machined so that it will just fit over the bearing journal and an outside diameter that will just fit inside the roller bearing cone (602) that is still on the shaft. **Make sure** that the roller cage does not rest on the tube.
 - 2.3.16. Press the shaft (500) down through the inner bearing (603), inner bearing spacer (550), spiral bevel pinion (100), oil slinger plate (20) and the outer bearing (602).
 - 2.3.17. Remove the outer bearing cups (602) from the horizontal carrier (15) using a brass punch or bearing puller.
- 2.4. There is no need to remove the oil slinger (570) from the oil slinger plate (20), unless one or the other is damaged. In which case the new part must be positioned exactly as the old one in order to achieve proper lubrication.

3.0. Disassembly of the Intermediate Shaft Assembly.

- 3.1. Remove hub type spiral bevel gears (100, Fig. 1) and the upper intermediate bearing cone (604) by blocking under the gear hub and pressing on the end of the intermediate shaft (200). Remove gear mount (22) ring type spiral bevel gears (100, Fig. 2) in the same manner, but first remove the ring gear from the gear mount by removing the cap screws and hitting lightly on the back of the gear with a **soft mallet**. **NOTE:** Most gear drives have spacers (450 and 451) located above and below the gear (100).
- 3.2. Remove the gear key (910) and the between gear spacer (451).
- 3.3. Remove the lower intermediate bearing cone (605) by blocking under it and pressing the intermediate shaft (200) down through it,
- 3.4. Remove the below gear spacer (453).
- 3.5. **DO NOT INTERCHANGE THE ABOVE GEAR SPACER (450), THE BETWEEN GEAR SPACER (451) OR THE BELOW GEAR SPACER (453) AT ASSEMBLY.**

4.0. Disassembly of the Output Shaft Assembly.

- 4.1. Remove the helical gear (200), output shaft spacer (452) and lower output bearing cone (601) by blocking under the gear hub and pressing on the end of the output shaft (400).
- 4.2. Remove the upper output bearing cone (600) by blocking under it and pressing the output shaft (400) down through it.

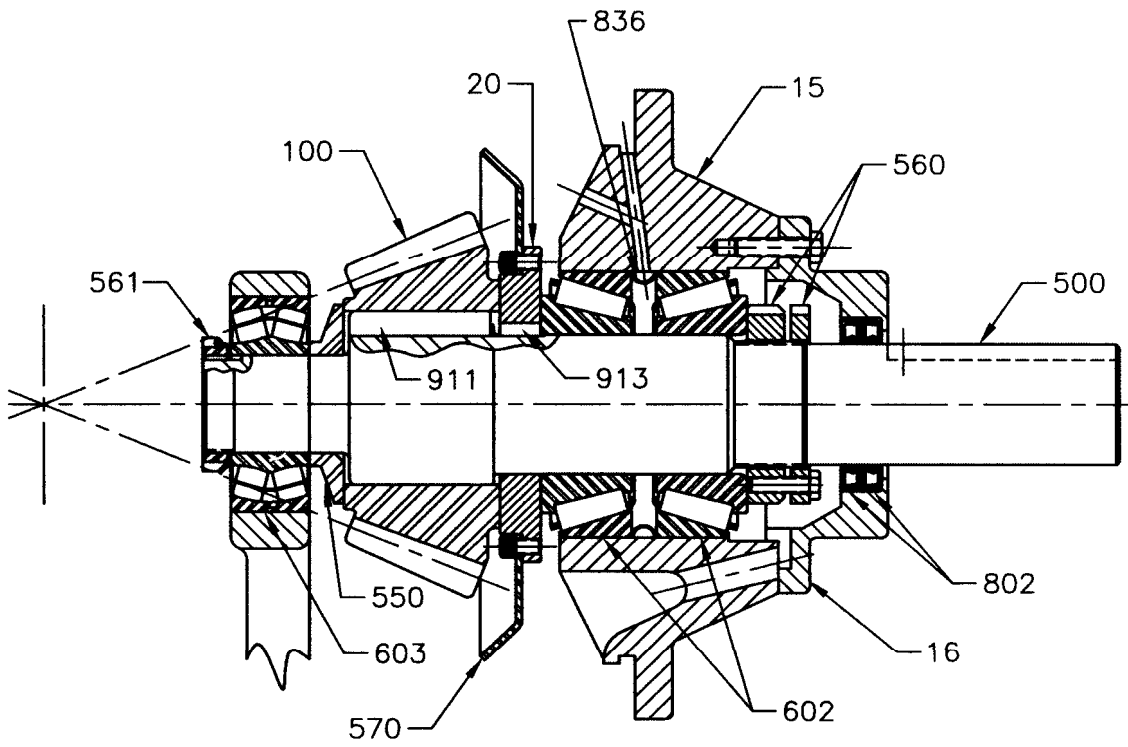

MODEL 1311, 1712 & 1713
 HORIZONTAL ASSEMBLY
 WITH INNER SPACER
 FIGURE 7

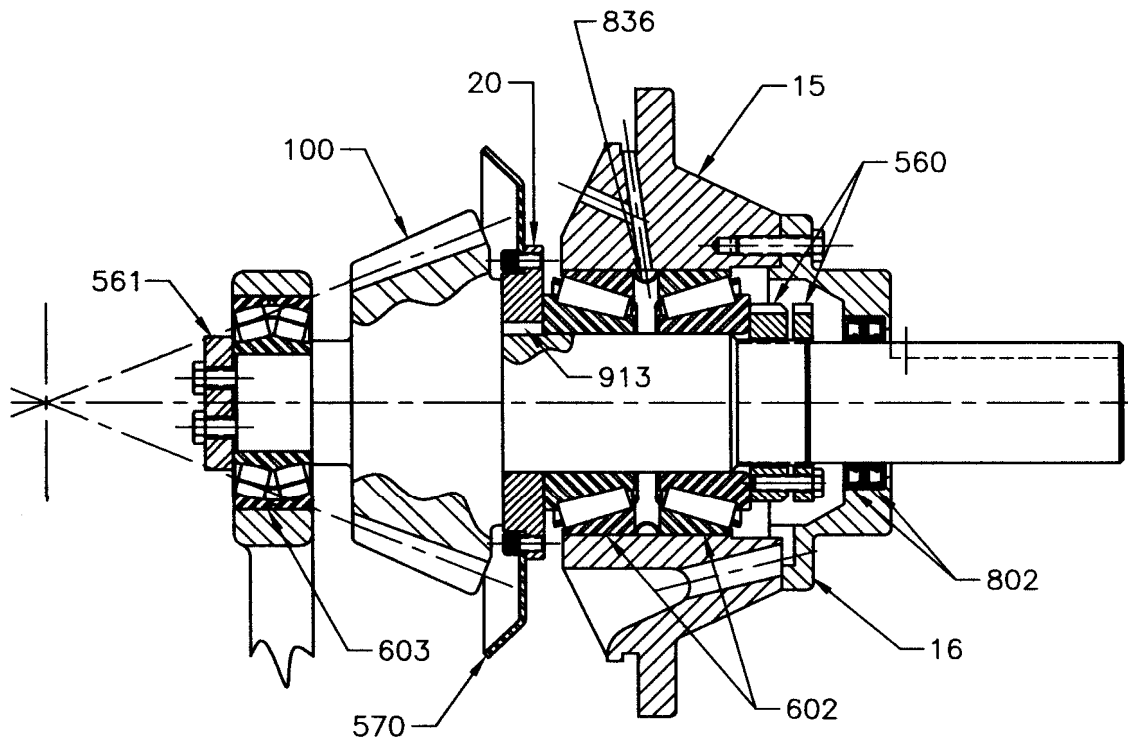

MODEL 1311, 1712 & 1713
 HORIZONTAL ASSEMBLY
 STEM PINION
 FIGURE 8

5.0. General Assembly Instructions.

- 5.1. Refer to the appropriate cross sectional drawing during assembly. See Fig. 1 or Fig. 2.
- 5.2. Wash all disassembled parts and housings thoroughly with clean solvent.
- 5.3. Check the new spiral bevel gear set (if it is required) to make certain it is a matched set. Our spiral bevel gears are lapped in matched sets at the factory and must not be separated. Each set of gears is assigned a serial number which is etched on each member of the set. The serial number is etched on the back face of the gear and pinion members just behind the heel of the tooth, along with the mounting distance of the particular member, its part number and the minimum amount of backlash for the gear set.
- 5.4. Do not remove new bearings from their cartons until they are needed for use. Wash all used bearings in clean solvent. **WARNING:** Do not spin dry the bearings with pressurized air. Lubricate each bearing and roll the cone in its cup to check for any roughness. If the bearings are not going to be used immediately after cleaning, lubricate them and then cover each one to protect against contamination.
- 5.5. If new replacement parts have been purchased from the factory, make sure that there are no burrs on the shoulders that could cause problems in assembly.
- 5.6. When pressing **ANY** component on a shaft or into a housing, **ALWAYS** use an antigalling compound.
- 5.7. The correct spiral bevel gear positions are obtained through the use of spacers (453 and 20). The required spacer lengths will vary with changes in the mounting distances (M.D.) of the gears. Spacer lengths should be corrected if the M.D. of the new set of gears differs more than 0.003 inch from the M.D. of the old set of gears. Usually bearing dimensions are consistent enough so that even if they are replaced, spacer changes are not required. If the gear case (10) or the horizontal shaft carrier (15) is ever replaced, the assembled castings will have to be remeasured and the spacers changed accordingly.

6.0. Assembly of the Output Shaft Assembly.

- 6.1. Set the helical gear (200) in the press on blocks so that the output shaft (400) can be pressed down through it.
- 6.2. Insert the helical gear key (912) into the keyway of the shaft.
- 6.3. Set the output shaft in the helical gear (200).
- 6.4. Press the shaft down through the gear until the gear rests firmly against the shaft shoulder.
- 6.5. Raise the shaft off the press and set the lower output bearing cone (601) along with the output shaft spacer (451) under the helical gear (200). **NOTE:** The lower bearing cannot rest flat on the table of the press. A sleeve must be used under the bearing. The sleeve must have an inside diameter larger than the outside diameter of the bearing journal and an outside diameter smaller than the inside diameter of the roller cage.
- 6.6. Lower the shaft extension into the lower output bearing (601).
- 6.7. Press the output shaft (400) down into the lower bearing until the output shaft spacer (452) is tight against the helical gear (200).
- 6.8. Press the upper output bearing cone (600) onto the shaft until it is tight against the shoulder of the shaft. **NOTE:** Take care not to damage the bearing roller cage. The bearing pusher **must not** bear against the cage or rollers.

7.0. Assembly of the Intermediate Shaft Assembly.

- 7.1. **NOTE:** If the helical pinion shaft (200) has to be replaced by a new pinion shaft, there will have to be some measurements taken. Both the old and new shafts will have to be measured across the teeth of the pinion from the shoulder where the between gear spacer (451) locates to the shoulder where the below gear spacer (453) locates. The measurements must be taken with a micrometer or vernier caliper. Compare the measurements. If the difference is less than or equal to 0.002 inch, no change will need to be made in the below gear spacer. If the difference is more than 0.002 inch, the below gear spacer will have to be changed accordingly.

7.1.1 Example:

Model:	1712
	Shoulder to Shoulder
Old pinion shaft	6.934 inch
New pinion shaft	6.937 inch

Difference	-0.003 inch

0.003 inch of stock will need to be removed from the below gear spacer (453). **NOTE:** When removing stock from spacers, use a surface grinder or a lathe with the spacer mounted on a mandrel. The ends of the spacer must be parallel to each other and perpendicular to the bore.

- 7.2. **NOTE:** If the gear drive uses a gear mount (22) with the vertical spiral bevel gear (100) and it has to be replaced, proceed to step 20.0.
- 7.3. Slide on the between gear spacer (451).
- 7.4. Insert the spiral bevel gear key (910).
- 7.5. Press the vertical spiral bevel gear (100) or gear mount (22), whichever is applicable, onto the shaft (200).
- 7.6. Slide on the above gear spacer (450).
- 7.7. Press on the upper intermediate bearing cone (604). **NOTE:** Take care not to damage the bearing roller cage.
- 7.8. Invert the shaft and slide on the below gear spacer (453).
- 7.9. Press on the lower intermediate bearing cone (605). **NOTE:** Take care not to damage the bearing roller cage.
- 7.10. Double check to see that all parts are completely pressed together. Spacers should not turn on the shaft.
- 7.11. Install the spiral bevel ring gear (100) onto the gear mount (22), if applicable. Pull the gear onto the gear mount evenly and squarely, using the cap screws. Make sure that the gear does not cock or bind and that it is fully seated on the gear mount.

8.0. Assembly of the Input Shaft Assembly.

- 8.1. Attach the oil slinger (570) to the oil slinger plate (20). On the models 1008, 1110 and 1311 the slinger is mounted as shown in Fig. 5. On the models 1712 and 1713 the slinger is mounted as shown in Fig. 7.
- 8.2. Assembly of the input shaft assembly for the models 1008 and 1110.
 - 8.2.1. Press the inner (603) and outer (602) bearing cups into the horizontal shaft carrier (15).
 - 8.2.2. Two types of input shaft assemblies are used on these models. One type requires the use of a horizontal gear retainer (561). The other type does not. See Fig. 4, Fig. 5 or Fig. 6.
 - 8.2.3. If the unit being repaired uses the horizontal gear retainer (561), proceed to the next step. If not, proceed to step 8.2.13.
 - 8.2.4. Place the input shaft (500) in the press so that the end of the shaft where the gear retainer mounts points up.
 - 8.2.5. Installation of the oil slinger plate.
 - 8.2.5.1. On the model 1008, press on the oil slinger plate (20), with the oil slinger (570), keeping the top of the plate 1/16" to 1/8" above the journal that it was pressed onto. Make sure that the keyways in the plate and the shaft match so that the oil slinger plate key (913) can be inserted at this time.
 - 8.2.5.2. On the model 1110, insert the spiral bevel pinion key (911) into the keyway in the shaft. Press on the oil slinger plate (20), with the oil slinger (570), keeping the bottom of the plate 1/16" to 1/8" above the journal that inner bearing (603) presses onto.
 - 8.2.6. **Make certain** that the slinger is mounted as shown in Fig. 5.
 - 8.2.7. Insert the spiral bevel pinion key (911) into the keyway in the shaft (500). Note: This operation has already been done on the model 1110.
 - 8.2.8. Press the spiral bevel pinion (100) down against the oil slinger plate (20). Make sure that there are enough threads exposed so that the retainer (561) will not bottom out against the shaft shoulder before it comes into contact with the pinion.
 - 8.2.9. Slide the gear retainer lockwasher down on the shaft to rest against the spiral bevel pinion (100).
 - 8.2.10. Screw the gear retainer (561) tight against the lockwasher. Using a small drift punch or chisel, bend one of the tabs of the lockwasher over into one of the notches of the gear retainer.
 - 8.2.11. Invert the shaft (500) so that the gear retainer (561) is pointing down.
 - 8.2.12. Proceed to step 8.2.19.
 - 8.2.13. Place the input shaft (500) in the press so that the end that will have the drive flange mounted on it points up.
 - 8.2.14. Slide on the inner horizontal spacer (550), if applicable.
 - 8.2.15. Insert the spiral bevel pinion key (911) in the shaft keyway.
 - 8.2.16. Press on the spiral bevel pinion (100).
 - 8.2.17. Insert the oil slinger plate key (913), if applicable, in the shaft keyway.
 - 8.2.18. Press on the oil slinger plate (20), with the oil slinger (570). Make sure the slinger is mounted as shown in Fig. 5.
 - 8.2.19. Press the inner bearing cone (603) down against the oil slinger plate (20). **NOTE:** Take care not to damage the bearing roller cage. The bearing pusher **must not** bear against the cage or rollers.
 - 8.2.20. Slide the horizontal shaft carrier (15) down over the input shaft (500) until it is seated on the inner bearing cone (603).
 - 8.2.21. Press the outer bearing cone (602) onto the shaft (500), leaving approximately 0.010 to 0.020 inch clearance between the cup and cone. This clearance can be "felt" by lifting the horizontal carrier (15) while pressing the bearing cone in place. **NOTE:** Take care not to damage the bearing roller cage.
 - 8.2.22. Proceed to step 9.0.

- 8.3. Assembly of the input shaft assembly for the models 1311, 1712 and 1713.
 - 8.3.1. Press the inner cup of the outer bearing set (602) into the horizontal shaft carrier (15).
 - 8.3.2. Place oiling ring (836) against inner bearing race (602) making sure that split in oiling ring (836) is aligned with machined oil drain back hole in the bottom of horizontal shaft carrier (15). Make sure lip on oiling ring (836) does not overlap on to surface that the outer bearing race presses against, otherwise outer bearing race will not seat in its bore.
 - 8.3.3. Press the outer cup of the outer bearing set (602) into the horizontal carrier (15). After bearing race (602) is pressed into horizontal carrier (15), try to insert 0.002" feeler gauge between the bore in the horizontal carrier (15) and the bearing race (602). If feeler gauge can be inserted in any region, you must remove the bearing race (602) and clear any foreign debris from the respective bore so that bearing race (602) can be fully seated. After bearing race is pressed into horizontal carrier (15) make sure that split in oiling ring (836) is still aligned with oil drain back hole in horizontal shaft carrier (15).
 - 8.3.4. Place the input shaft (500) in the press so that the end on which the inner bearing retainer (561) mounts points up.
 - 8.3.5. There are three styles of input shaft assemblies used on these models. One is with the inner spacer (550) made as an integral part of the shaft (500), one is with the inner spacer made as a separate piece and the third is with the spacer and the spiral bevel pinion made as integral parts of the shaft. See Fig. 7 or Fig. 8. If the spacer is a separate piece, proceed to the next step. If it is an integral part of the shaft, proceed to step 8.3.14. Or if both the spacer and pinion are part of the shaft, proceed to step 19.0.
 - 8.3.6. Press on the oil slinger plate (20), with the oil slinger (570), keeping the top of the plate 1/16" to 1/8" above the journal that it was pressed onto. Make sure that the keyway in the plate and the keyway in the shaft (500) match so that the oil slinger plate key (913) can be inserted at this time. On the model 1311, the slinger should be mounted as shown in Fig. 5. On the models 1712 and 1713, the slinger should be mounted as shown in Fig. 7.
 - 8.3.7. Insert the spiral bevel pinion key (911) into the shaft keyway.
 - 8.3.8. Press the spiral bevel pinion (100) down against the oil slinger plate (20).
 - 8.3.9. Slide the inner bearing spacer (550) down over the shaft and let it rest on the pinion, Make sure that the spacer rests on the pinion and not on the shaft shoulder.
 - 8.3.10. Press the inner bearing (603) onto the shaft (500) and check to make sure that there are enough threads exposed so that the bearing retainer (561) will not bottom out against the shaft shoulder before it comes in contact with the bearing.
 - 8.3.11. Slide the bearing retainer lockwasher down on the shaft to rest against the inner bearing.
 - 8.3.12. Screw the bearing retainer (561) tight against the lockwasher. Using a small drift punch or chisel, bend one of the tabs of the lockwasher over into one of the notches of the retainer.
 - 8.3.13. Invert the shaft (500) so that the inner bearing (603) is pointing down.
 - 8.3.14. Proceed to step 8.3.22.
 - 8.3.15. Press the inner bearing (603) on completely against the shaft shoulder.
 - 8.3.16. Slide the bearing retainer lockwasher down on the shaft to rest against the inner bearing.
 - 8.3.17. Screw the bearing retainer (561) tight against the lockwasher. Using a small drift punch or chisel, bend one of the tabs of the lockwasher over into one of the notches of the retainer.
 - 8.3.18. Invert the shaft (500) so that the inner bearing (603) is pointing down.
 - 8.3.19. Insert the spiral bevel key (911) in the shaft keyway.
 - 8.3.20. Press the spiral bevel pinion (100) onto the shaft completely against the shoulder.
 - 8.3.21. Insert the oil slinger key (913) in the shaft keyway.
 - 8.3.22. Press on the oil slinger plate (20), with the oil slinger (570), against the spiral bevel pinion. On the model 1311, the slinger should be mounted as shown in Fig. 5. On the models 1712 and 1713, the slinger should be mounted as shown in Fig. 7.
 - 8.3.23. Press on the inner cone of the outer bearing set (602). **NOTE:** Take care not to damage the roller cage. The bearing pusher **must not** bear against the cage or rollers.
 - 8.3.24. Slide the horizontal shaft carrier (15) down over the input shaft (500) until it is seated on the inner cone of the outer bearing set (602).
 - 8.3.25. Press the outer cone of the outer bearing set (602) onto the shaft (500), leaving approximately 0.010 to 0.020 inch axial clearance between the cup and cone. This clearance can be "felt" by lifting the horizontal carrier (15) while pressing the bearing cone into place. **NOTE:** Take care not to damage the roller cage.

9.0. Installation of the Shaft Assemblies into the Gear Case.

- 9.1. Press the lower output (601) and intermediate (605) bearing cups into the gear case (10).
- 9.2. Place a gasket on the horizontal shaft carrier (15). **WARNING:** Do not place the gasket over the oil port.
- 9.3. Mark the teeth of the spiral bevel pinion with a suitable marking compound.
- 9.4. Insert the input shaft assembly (15) into the horizontal opening in the gear case (10). Two guide pins, studs or headless bolts, turned into the tapped holes around the opening will greatly assist in installing the horizontal assembly. **NOTE:** Make sure on the models 1311, 1712 and 1713 that the inner bearing (603) has started squarely into the bearing carrier in the gear case and has not cocked.
- 9.5. Pull the horizontal assembly up to the gear case with cap screws. **MAKE SURE THAT THE MATCH MARKS ON THE HORIZONTAL CARRIER AND THE GEAR CASE ARE ALIGNED.**
- 9.6. Mark the timing marks on the vertical spiral bevel gear (100) (intermediate shaft assembly) with chalk for later referencing.
- 9.7. The output and intermediate shaft assemblies will have to be lowered into the gear case (10) with a strong back as described in step 1.14. The strong back is used to prevent damage to the lower bearings (601 and 605) and to the helical gears (200).
- 9.8. Lower the output and intermediate shaft assemblies into the gear case (10). **NOTE:** Make sure that the lower intermediate bearing cone (605) clears the horizontal gear retainer (561) or inner bearing retainer (561), whichever is applicable. Also make sure that the timing marks on the spiral bevel gear are aligned with the timing mark on the spiral bevel pinion.
- 9.9. Replace any oil lines that had to be removed in the positions noted during disassembly, if applicable.
- 9.10. Coat the top flange of the gear case (10) with plastic lead seal (or equivalent). **WARNING:** Do not fill the oil ports with the plastic lead seal.
- 9.11. Lower the vertical cover (12) onto the gear case and align with the two tapered pins. Secure with the cap screws.
- 9.12. Slide the upper output bearing cup (600) down against the upper output bearing cone.
- 9.13. Slide the upper intermediate bearing cup (604) down against the upper intermediate bearing cone.
- 9.14. Reconnect the 3/8" oil line, if applicable, from the vertical cover (12) to the oil line distribution block located just inside and to the left of the side inspection plate opening.

10.0. Adjustment of the Input Shaft Bearings.

- 10.1. Thread the thicker portion of the two locknuts (560) on the input shaft (500). **NOTE:** The thick member of the locknut set has one ground surface and one turned surface. The ground surface goes against the outer bearing cone (602).
- 10.2. Mount a dial indicator between the horizontal carrier (15) and the end of the input shaft (500), so that the axial movement of the shaft can be measured.
- 10.3. Tighten the locknut (560) until the in and out movement (bearing clearance) is from 0.001 to 0.002 inch T.I.R. for models 1008 and 1110, or 0.003 to 0.004 for models 1311 thru 1713. **NOTE:** The input shaft should be rotated several revolutions before each reading, so that the bearing cones will remain seated in their cups.
- 10.4. Remove the dial indicator and thread the thinner portion of the locknut (560) on the input shaft (500) to within 1/32 to 1/16 inch of the thicker portion of the locknut set. **NOTE:** Do not butt the two locknuts together.
- 10.5. Align the holes in the locknut set and thread the cap screws into the set. Tighten until the outer nut deflects and almost touches the inner nut.

11.0. Backlash Check.

Backlash is the amount of clearance between the mating teeth of a gear set and is obtained by measuring the amount of movement of one member at the pitch diameter when the other member is held stationary. Backlash is very difficult to measure in an assembled gear drive. Following is an indirect method of measuring backlash.

- 11.1. Lower the upper intermediate bearing cover (19), without the shim pack, onto the top of the upper bearing cup (604). The shim pack is left out at this time so that the bearing cover can be used to lock the intermediate shaft down during the backlash check.
- 11.2. While rotating the intermediate shaft (200) back and forth, alternately tighten two of the cap screws on opposite sides of the bearing cover (19) until the shaft becomes hard to rotate by hand.
- 11.3. Place a key in the keyway in the input shaft (500) and retain with a C-Clamp, so there is no movement between the key and the shaft.
- 11.4. Place a dial indicator against the key and set to zero.
- 11.5. Measure the distance from the center of the input shaft (500) to the point where the indicator contacts the key. See Fig. 9. This is the "r" value in the equation used in step 11.7.
- 11.6. Rotate the input shaft (500) back and forth and record the total indicator reading. This is the value "M" used in step 11.7. The intermediate shaft (200) should still be locked down at this time. This measurement is not accurate if **any movement** is observed in the intermediate shaft.

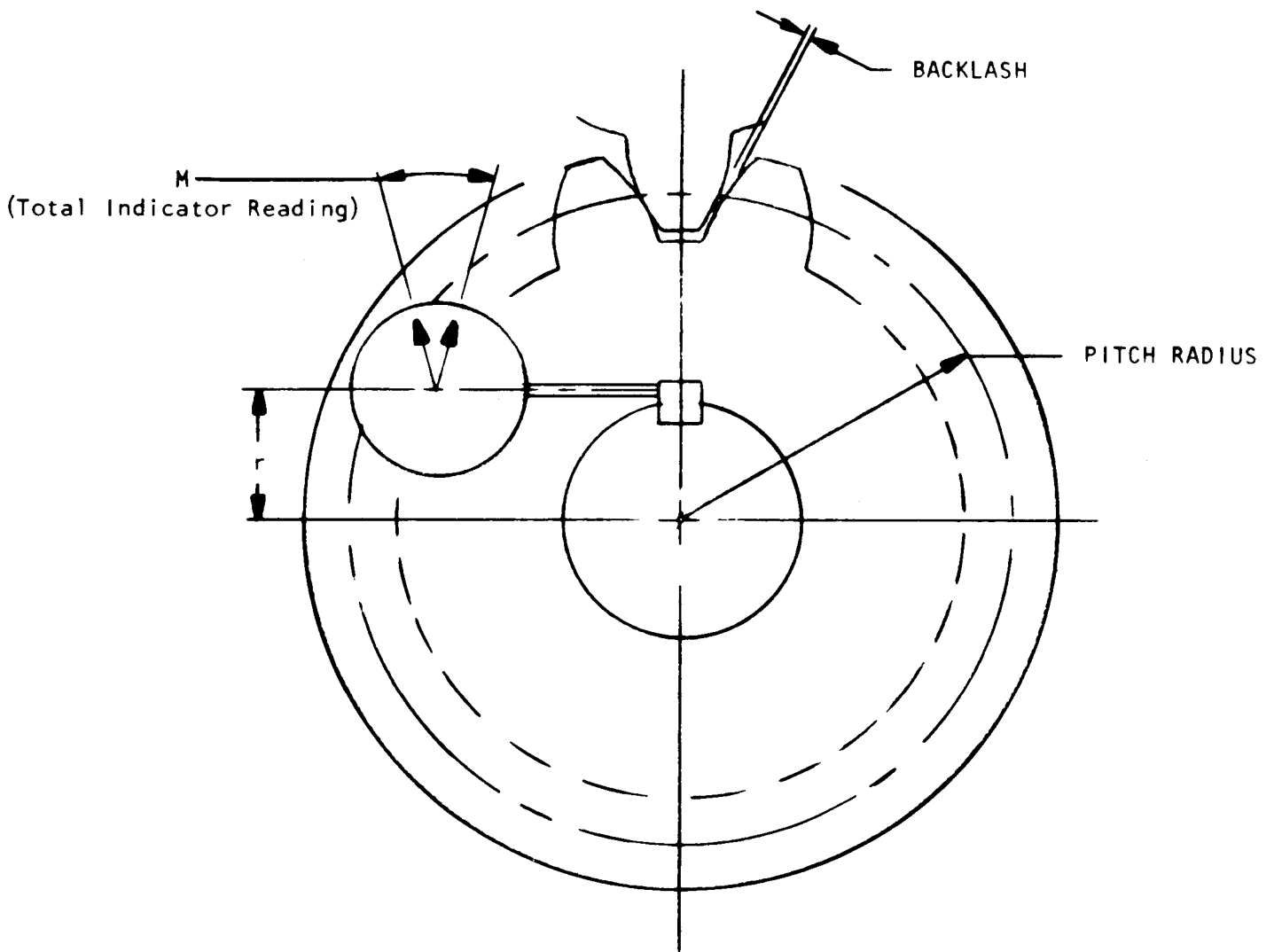

BACKLASH CHECK
FIGURE 9

11.7. Calculate the backlash using the following equation. The “C” value can be found in Table 3. **NOTE:** The ratio in Table 3 is the total ratio of the gear drive.

$$\text{Backlash} = \frac{(C) (M)}{r}$$

RATIO	C				
	1008	1110	1311	1712	1713
6.7:1		3.857			
7.5:1		3.500			
8:1	2.875	3.454			
8.7:1	2.556				
9:1	2.556			3.760	
9.5:1	2.375	2.942			
10:1	2.333	2.750	3.375	3.512	
11:1	2.083	2.488	3.000	3.115	
12:1	1.918	2.303	2.750	2.786	
13:1	1.772	2.125	2.585	2.685	3.728
14:1	1.645	1.955	2.400	2.483	3.115
15:1			2.250	2.333	2.786
16:1			2.066		
16.5:1				2.102	
16.857:1				2.062	
17:1					2.483
18:1					
18.5:1					2.333
19:1				1.856	
20:1					2.141

Table 3

11.7.1. Example:

Model: 1311

Ratio: 12:1

“r” is measured to be 1.375 inches.

“M” is measured to be 0.008 inches.

“C” is found in the table to be 2.750

Therefore:

$$\text{Backlash} = \frac{(C) (M)}{r} = \frac{(2.750) (0.008)}{1.375}$$

Backlash = 0.016 inch

- 11.8. The amount of backlash **must not** be less than the amount etched on the gear set. However, it can be as high as two times the etched value. **NOTE:** If the backlash is not within the limits stated above, it must be corrected. Refer to step 22.0 after performing the Tooth Bearing Check. **NEVER** run the spiral bevel gears without backlash.

12.0. Spiral Bevel Tooth Contact Pattern Check.

- 12.1. Loosen the two cap screws in the upper intermediate bearing cover (19) until the intermediate shaft (200) rotates with a slight amount of drag.
- 12.2. Apply a suitable marking compound to the teeth of the spiral bevel gears (100) and rotate the input shaft.
- 12.3. Compare the tooth contact pattern to the patterns shown in step 21.0.
- 12.4. If required, make adjustments to correct any error in the tooth contact pattern according to the instructions in step 21.0.

13.0. Adjustment of the Intermediate Shaft Bearings.

- 13.1. Remove the upper intermediate bearing cover (19) and insert a trial shim pack. The thickness of the shim pack must be enough to allow the intermediate shaft (200) to be raised when the upper bearing cover is bolted down.
- 13.2. Replace the upper bearing cover (19) and tighten the bolts.
- 13.3. Thread a long bolt into the end of the intermediate shaft (200). **NOTE:** The bolt must be threaded tightly into the shaft, so no movement is felt between the bolt and the shaft.
- 13.4. Rotate the shaft several revolutions to seat the bearing cones in their cups.
- 13.5. Mount a dial indicator between the bolt and the vertical cover (12), so that the up and down movement of the intermediate shaft can be measured.
- 13.6. Insert a pry bar through the side inspection opening and place its end under the spiral bevel gear hub (100) or gear mount (22) (whichever is applicable).
- 13.7. While watching the indicator, pry up on the spiral bevel gear. Record this measurement. **NOTE:** The intermediate shaft **must be** rotated before each measurement.
- 13.8. **CAUTION: DO NOT PRY ON OR LET THE BAR HIT THE GEAR TEETH DURING THIS OPERATION.**
- 13.9. Remove the upper bearing cover (19) and enough shims to decrease the measurement taken in step 13.7 to 0.000 to 0.001 inch. 0.002 inch shims removed will decrease the end play 0.002 inch. **NOTE:** The shims in a shim pack have different thicknesses.
 - 13.9.1. Example:

If the indicator reads 0.006 inch, remove 0.005 to 0.006 inches of shims from the shim pack.
- 13.10. Replace the upper bearing cover (19) with the shim pack and double check the measurement. **NOTE: THE MATCH MARKS ON THE UPPER BEARING COVER AND THE VERTICAL COVER MUST BE ALIGNED.**
- 13.11. If the measurement is not within the limits, repeat steps 13.9 and 13.10.

14.0. Adjustment of the Output Shaft Bearings.

- 14.1. Lower the vertical seal carrier (21) (without the vertical seals (815)) and a trial shim pack onto the upper output bearing (600). The thickness of the shim pack must be enough to allow the output shaft (400) to be raised when the seal carrier is bolted down.
- 14.2. Tighten the bolts on the seal carrier.
- 14.3. Rotate the output shaft (400) several revolutions to seat the output bearing cones in their cups.
- 14.4. Mount a dial indicator between the output shaft and the vertical cover (12), so that the up and down movement of the shaft can be measured.

- 14.5. Thread an eye bolt into the top of the output shaft (400).
- 14.6. While watching the indicator, pull up on the output shaft with a hoist. Record this measurement. **NOTE:** The output shaft **must be** rotated before each measurement.
- 14.7. Remove the vertical seal carrier (21) and enough shims to decrease the measurement taken in step 14.6 to 0.001 to 0.003 inch preload. 0.002 inch shims removed will decrease the end play 0.002 inch. **NOTE:** The shims in a shim pack have different thicknesses.
 - 14.7.1. Example:
If the indicator reads 0.006 inch, remove 0.007 to 0.009 inches of shims from the shim pack.
- 14.8. Replace the vertical seal carrier (21) with the shim pack and double check the measurement.
- 14.9. If any movement is seen in the dial indicator, repeat steps 14.7 and 14.8.

15.0. Completion of Assembly.

- 15.1. Remove the vertical seal carrier (21) and press the vertical seals (815) into place (spring sides facing each other) and pack with grease. (Refer to the Operating and Maintenance Instructions for the proper type of grease.)
- 15.2. Replace the vertical seal carrier (21) with the vertical seals and correct shim pack. **NOTE: THE MATCH MARKS ON THE SEAL CARRIER AND THE VERTICAL COVER MUST BE ALIGNED.**
- 15.3. Mount the upper seal plate (11) and tighten the three set screws. Check to make certain that it is not touching the vertical seal carrier (21).
- 15.4. Press the input oil seals (802) into the oil seal plate (16). Mount the seals front to back and pack with grease. (Refer to the Operating and Maintenance Instructions for the proper type of grease.) The seals are mounted with the springs facing inside the case.
- 15.5. Slide the seal plate (16) with its gasket onto the input shaft (500). **NOTE:** Put tape over the input shaft keyway to protect the seals from being cut by the edges of the keyway. **WARNING:** Do not put the gasket over the oil drain back port. The oil drain ports in the oil seal plate and the horizontal shaft carrier (15) must be aligned.
- 15.6. Center the oil seal plate on the input shaft and tighten the cap screws.
- 15.7. Tip the unit back so that the input shaft (500) is pointing up.
- 15.8. Replace the lower output bearing cover (17A) with its gasket.
- 15.9. If the unit is supplied with an oil pump (300), proceed to step 17.0. If not, replace the lower intermediate bearing cover (17B) with its gasket.
- 15.10. Place the unit back down on its base.
- 15.11. Replace the upper inspection plate (18) with its gasket.
- 15.12. Fill the unit with the correct lubricant (see the Operating and Maintenance Instructions), affix the side inspection plate with its gasket and return the drive to service.

16.0. Disassembly of the Oil Pump.

- 16.1. Refer to Fig. 10 during disassembly.
- 16.2. Match mark the oil pump (300), oil pump mounting plate (17M) and gear case (10).
- 16.3. Remove the cap screws holding the oil pump mounting plate to the gear case.
- 16.4. Remove the oil pump mounting plate (17M) and oil pump (300).
- 16.5. Remove the cap screws holding the oil pump to the mounting plate.
- 16.6. Separate the oil pump from the mounting plate.
- 16.7. Proceed to step 1.22.

17.0. Assembly of the Oil Pump.

- 17.1. Refer to Fig. 10 during assembly.
- 17.2. Be sure to wash the oil pump thoroughly with clean solvent.
- 17.3. Place the oil pump drive plate (303) on the end of the intermediate shaft (200) and retain with the socket head cap screws.
- 17.4. Place a gasket on the oil pump mounting plate (17M). **Make sure** that the oil pump discharge port has not been covered by the gasket.
- 17.5. Insert the mounting plate into the gear case (10) and tighten the cap screws. **NOTE: THE MATCH MARKS ON THE MOUNTING PLATE AND THE GEAR CASE MUST BE ALIGNED.**
- 17.6. Place a gasket on the oil pump (300). **Make sure** that the suction and discharge ports have not been covered by the gasket.
- 17.7. Insert the oil pump into the oil pump mounting plate (17M) making sure that the oil pump shaft goes into the slot in the oil pump drive plate (303). **NOTE: THE MATCH MARKS ON THE OIL PUMP AND THE MOUNTING PLATE MUST BE ALIGNED.**
- 17.8. Tighten the cap screws in the oil pump.
- 17.9. Proceed to step 15.10.

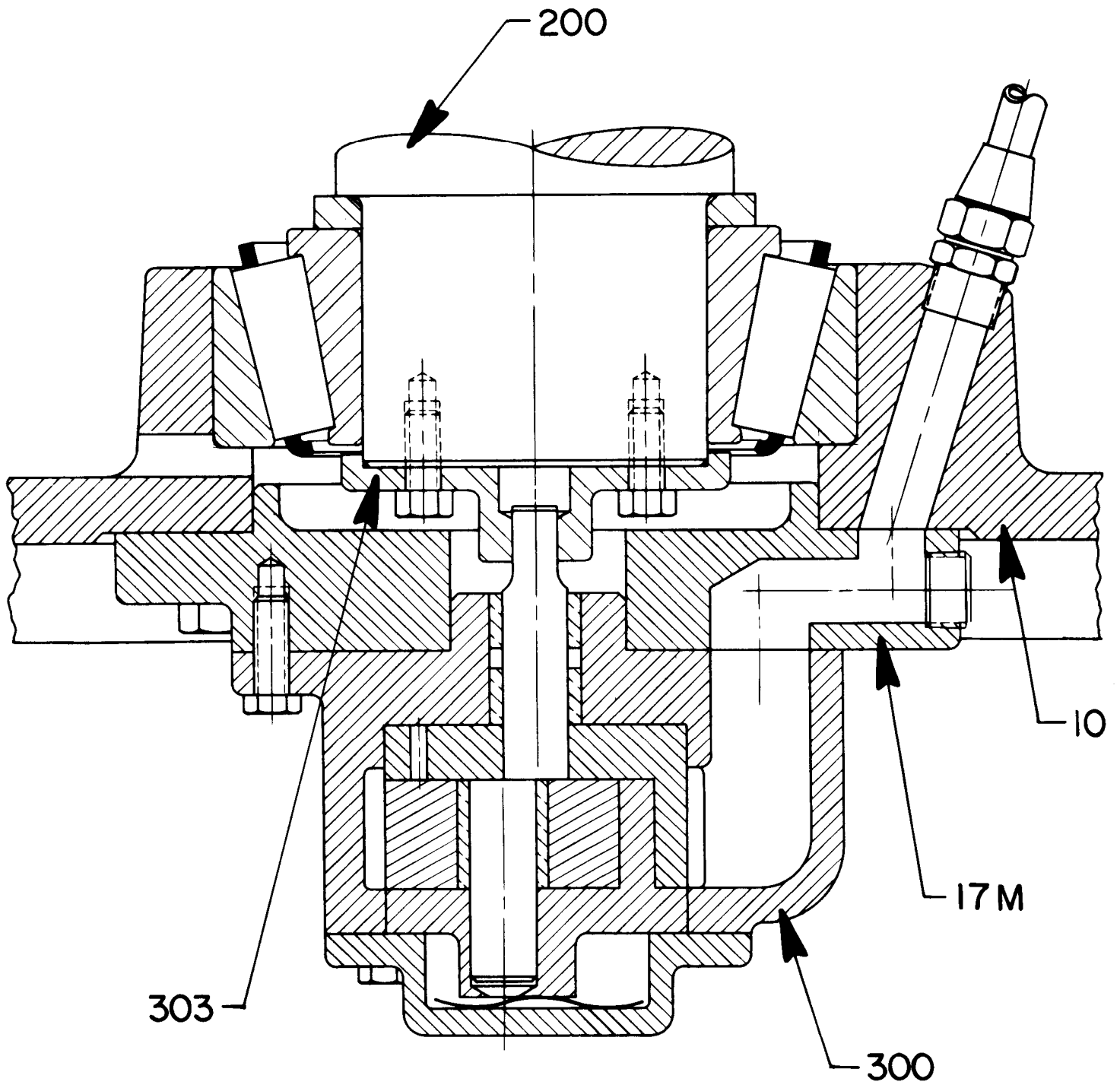

OIL PUMP
FIGURE 10

18.0. Disassembly of the Input Stem Pinion Assembly.

- 18.1. Refer to Fig. 11 during disassembly.
- 18.2. Make a note as to which direction the oil slinger (570) is mounted. Remove the oil slinger.
- 18.3. Remove the inner bearing retainer (560) by removing the two socket head cap screws.
- 18.4. Place the assembly in the press with the inner bearing (603) pointing up. Support the inner bearing with two square bars resting on a tube of sufficient length to hold the assembly above the table of the press. The tube should have an inside diameter that will allow the assembly to fit inside.
- 18.5. Press the inner bearing (603) off the shaft (500).
- 18.6. Reposition the stem pinion shaft (100) so that the oil slinger plate (20) is supported by a tube that has an inner diameter slightly larger than the outside diameter of the pinion.
- 18.7. Press the stem pinion shaft (100) down through outer bearing (602) and the oil slinger plate (20). **NOTE:** When pressing against the oil slinger plate, take care not to damage the plate.
- 18.8. Proceed to step 2.3.17.

19.0. Assembly of the Input Stem Pinion Assembly.

- 19.1. Refer to Fig. 11 during assembly.
- 19.2. Press the inner bearing (603) on completely against the shaft shoulder.
- 19.3. Invert the stem pinion shaft (100) so that the inner bearing (603) is pointing down.
- 19.4. Insert the oil slinger key (913) in the shaft keyway.
- 19.5. Press on the oil slinger plate (20), with the oil slinger (570), against the spiral bevel pinion. On the model 1311, the slinger should be mounted as shown in Fig. 5. On the models 1712 and 1713, the slinger should be mounted as shown in Fig. 11.
- 19.6. Press on the inner portion of the outer bearing set (602). **NOTE:** Take care not to damage the roller cage. The bearing pusher **must not** bear against the cage or rollers.
- 19.7. Slide the horizontal shaft carrier (15) down over the stem pinion shaft (100) until it is seated on the inner portion of the outer bearing set (602).
- 19.8. Press the outer portion of the outer bearing set (602) onto the stem pinion shaft (100), leaving approximately 0.010 to 0.020 inch axial clearance between the cup and cone. This clearance can be "felt" by lifting the horizontal carrier (15) while pressing the bearing cone into place. **NOTE:** Take care not to damage the roller cage.
- 19.9. Place the inner bearing retainer (561) on the end of the stem pinion shaft and retain with the socket head cap screws.
- 19.10. Proceed to step 9.0.

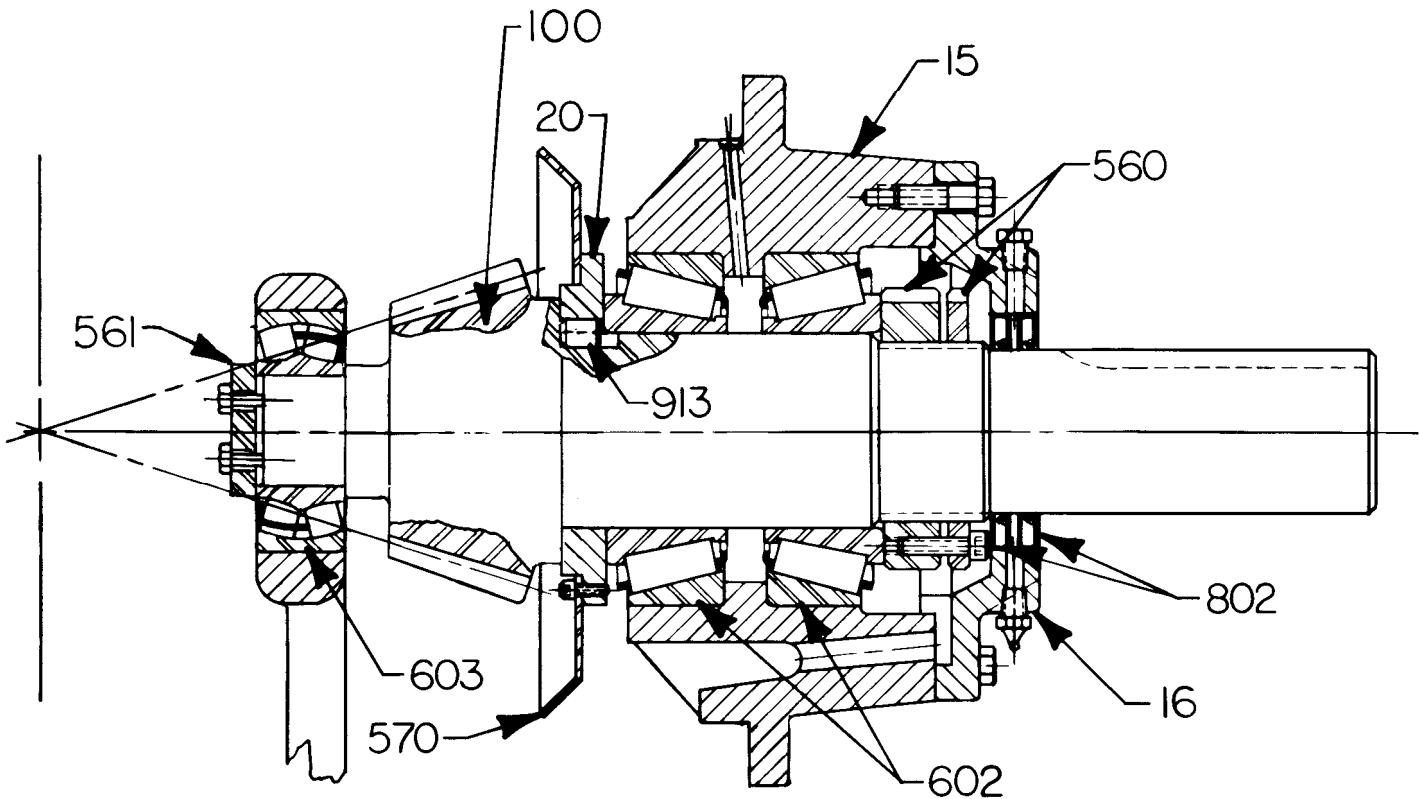

HORIZONTAL STEM PINION ASSB'Y

FIGURE 11

20.0. Installation of New Gear Mount.

- 20.1. Gear mounts as supplied by the factory are not finish machined on the gear mounting surfaces. These features are machined after the gear mount is assembled on the intermediate shaft to assure that the ring gear will be perfectly centered. This operation will require the use of a lathe with means of driving the shaft between centers.
- 20.2. Slide the between gear spacer (451) onto the intermediate shaft (200). See Fig. 12.
- 20.3. Insert the spiral bevel gear key (910) into the keyway in the shaft.
- 20.4. Press the new gear mount (22) onto the shaft (200). Make sure the gear mount is pressed tightly against the between gear spacer (451).
- 20.5. Remove the shaft from the press and place between the centers in the lathe.
- 20.6. Machine surface "A", taking a 0.005" to 0.015" cut.
- 20.7. Machine diameter "D" to the dimension shown in Fig. 12.
- 20.8. Machine surface "B", holding "T" to the same thickness as the original gear mount.
- 20.9. Clean the cast iron dust from the shaft and gear mount.
- 20.10. Remove the shaft from the lathe and proceed to step 7.6.

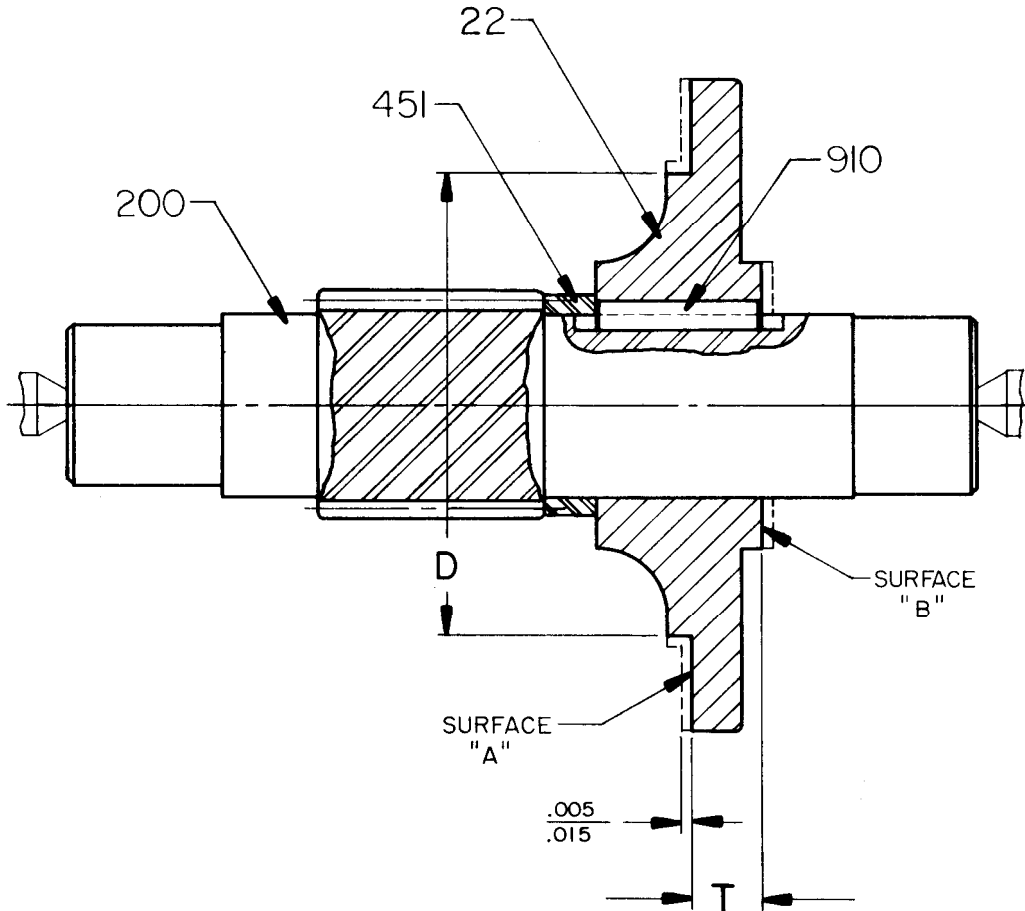

MODEL	D ^{+.0000} / _{-.0005}	T
1311	8.5000	✱
1712	11.0000	✱
1713	11.0000	✱

*DIMENSION "T": MEASURE "T" ON OLD GEAR MOUNT AND MACHINE NEW GEAR MOUNT TO THE SAME DIMENSION

NEW GEAR MOUNT

FIGURE 12

21.0. Spiral Bevel Tooth Contact Pattern and Adjustment.

- 21.1. The spiral bevel tooth contact pattern must be checked and corrected, if needed, before the backlash is corrected. The correct tooth contact for a spiral bevel gear set is shown in Fig. 13. If the tooth contact is correct proceed to step 22.0.
- 21.2. Fig. 14 shows the two most common forms of incorrect tooth contact. When a tooth contact occurs as shown in Fig. 14A, the following items will have to be checked.
 - 21.2.1. Make sure the horizontal shaft carrier (15) is pulled up tightly to the gear case (10).
 - 21.2.2. Make sure that no more than one gasket has been used between the horizontal carrier and the gear case.
 - 21.2.3. Make sure that the gasket used between the horizontal carrier and the gear case is 0.015" thick.
 - 21.2.4. If the above steps do not correct the tooth contact, then the spiral bevel pinion will have to be moved toward the gear by increasing the thickness of the oil slinger plate (20). An increase in the thickness of the plate of 0.001" will move the pinion 0.001".
- 21.3. When the tooth contact occurs as shown in Fig. 14B, the following items will have to be checked.
 - 21.3.1. Make sure that a gasket has been installed between the horizontal shaft carrier (15) and the gear case (10).
 - 21.3.2. Make sure that the gasket used between the horizontal carrier and the gear case is 0.015" thick.
 - 21.3.3. If the above steps do not correct the tooth contact then the spiral bevel pinion will have to be moved away from the gear. This is done by removing stock from the oil slinger plate (20). Removing 0.001" from the plate will move the pinion away from the gear 0.001". **NOTE:** Removal of stock from the plate **must be** done on a surface grinder.
- 21.4. When a tooth contact occurs as shown in Fig. 15 or Fig. 16, refer to the following instructions.
 - 21.4.1. The most probable cause of cross contact or shaft angle error is that the horizontal carrier is cocked in the register of the gear case.
 - 21.4.2. To correct, remove the input assembly and look for burrs, chips, a folded gasket or any condition that will prevent the horizontal housing from seating flat and square on the gear case. Contact the factory if the problem cannot be corrected.

22.0. Spiral Bevel Backlash Adjustment.

After the correct tooth contact is obtained, the backlash must be rechecked according to the procedure described in step 11.0. If the backlash is within limits proceed to step 13.0.

- 22.1. If the backlash is less than the amount etched on the spiral bevel gear set, the vertical gear will have to be moved away from the pinion. This is done by increasing the length of the below gear spacer (453). **NOTE:** When making a new spacer, the ends of the spacer must be parallel to each other and perpendicular to the bore.
- 22.2. If the backlash is greater than twice the amount etched on the gear set, the vertical spiral bevel gear will have to be moved toward the pinion. This is done by removing stock from the below gear spacer. (453). **NOTE:** Removal of stock from the spacer must be done on a surface grinder or on a lathe with the spacer mounted on a mandrel, to keep the ends of the spacer parallel to each other and perpendicular to the bore.
- 22.3. A change of 0.001" in the below gear spacer length will change the backlash 0.001".
- 22.4. When the backlash is within limits, proceed to step 13.0.

SPIRAL BEVEL GEARS—Typical Preferred Tooth Contact
 (Pinion Member Left Hand in All Cases Shown)

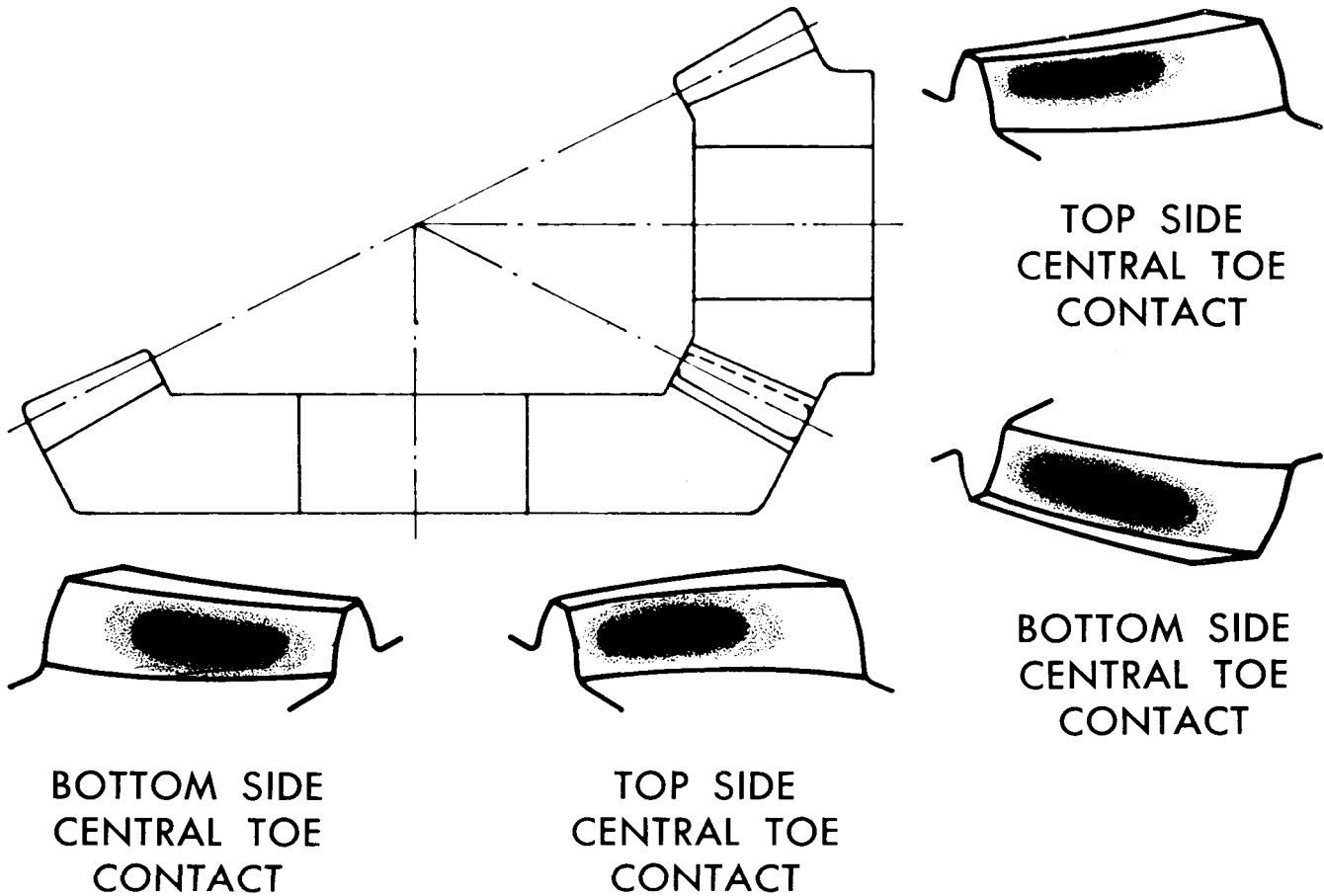

FIGURE 13

PROFILE ERROR—To Correct: move in on pinion cone.

PROFILE ERROR: To Correct: move out on pinion cone.

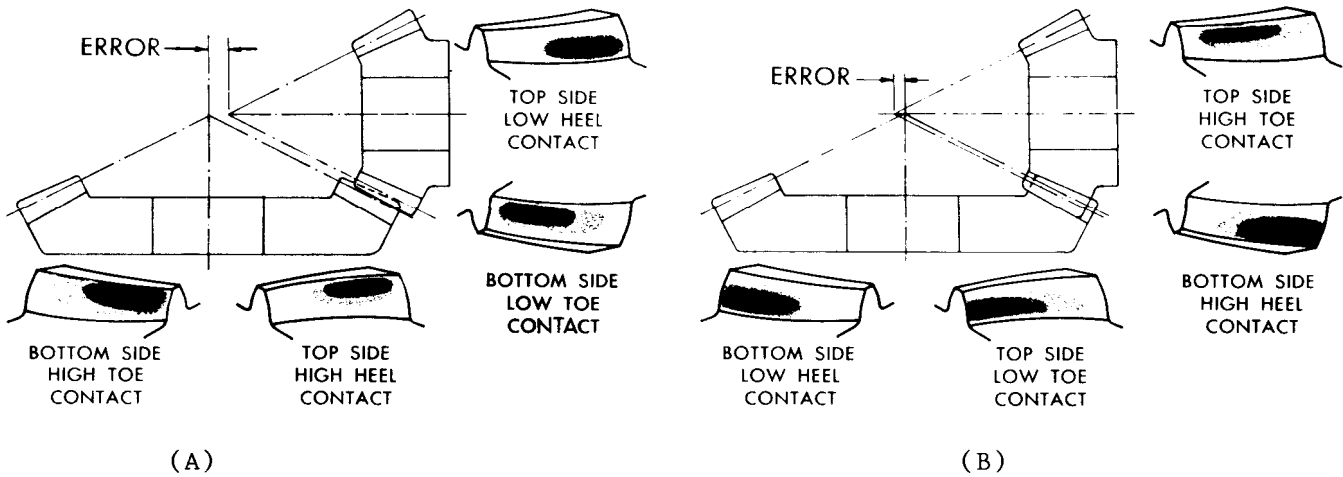
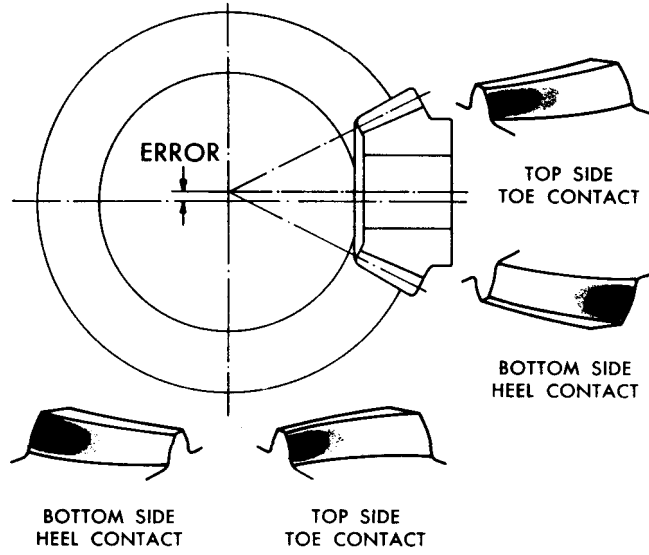

FIGURE 14

Proper profile contact and backlash must be obtained first before an attempt is made to correct for any of the following conditions if they should exist.

CROSS CONTACT-



CROSS CONTACT-

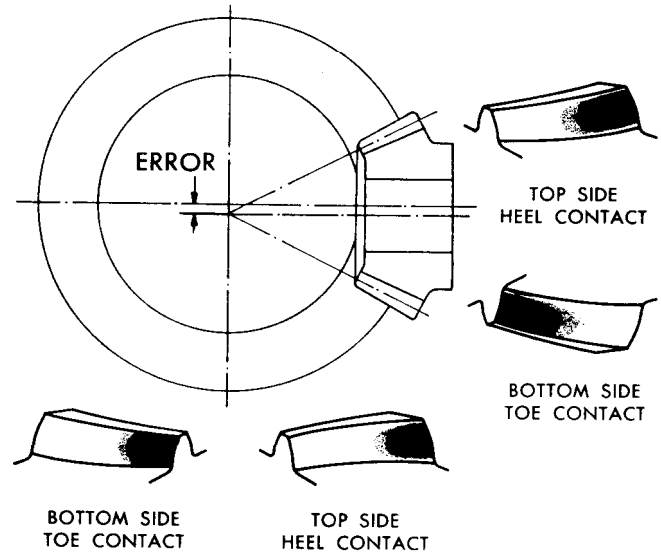
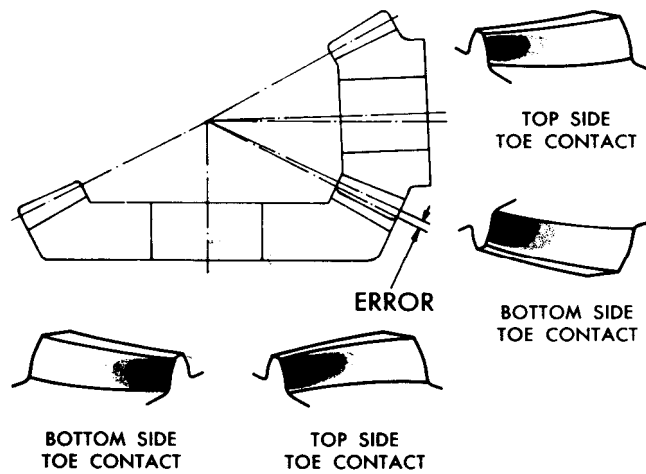

FIGURE 15

SHAFT ANGLE ERROR-



SHAFT ANGLE ERROR

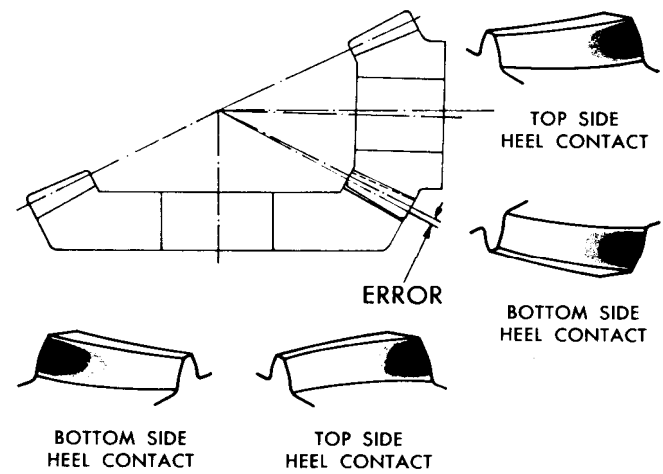

FIGURE 16

23.0.SHAFT SEALS

23.1. Input Shaft Seals.

- 23.1.1. Refer to Fig. 17 during installation.
- 23.1.2. Install seals (802) in the oil seal plate (16) so the springs will be toward the gear drive. Coat the lips of the seals with a thin film of grease, as specified in step 3.0.
- 23.1.3. Install the seal plate (16) on the horizontal carrier (15). Use a shield to protect the seals from being cut by the keyway in the shaft.
- 23.1.4. Insert a grease fitting into one port on the seal plate (16) and fill the seals with grease until it emerges from the other port. Use Mobile Grease #28.
- 23.1.5. Remove the grease fitting and install a plug in the bottom port.
- 23.1.6. After testing the gear drive, wipe off any grease that may have been purged from the seals and install a plug in the top port.

23.2. Output Shaft Seals

- 23.2.1. Refer to Fig. 18 during installation.
- 23.2.2. Install seals (815) in the vertical seal carrier (21) so the springs will be toward the gear drive. Coat the lips of the seals with a thin film of grease, as specified in step 3.0.
- 23.2.3. Install the seal carrier (21) on the vertical cover 12.
- 23.2.4. Insert a grease fitting into one port on the seal carrier (21) and fill the seals with grease until it emerges from the other port. Use Mobile Grease #28.
- 23.2.5. Remove the grease fitting and install a plug in the port.
- 23.2.6. Pack the area above the top seal up to the shoulder of the shaft with grease.
- 23.2.7. Apply a film of grease to the journal for the upper seal plate (11).
- 23.2.8. Install the upper seal plate (11) and tighten the three set screws. Wipe off any grease that may have pushed out around the upper seal plate.
- 23.2.9. After testing the gear drive, wipe off any grease that may have been purged from the seals and install a plug in the open port.

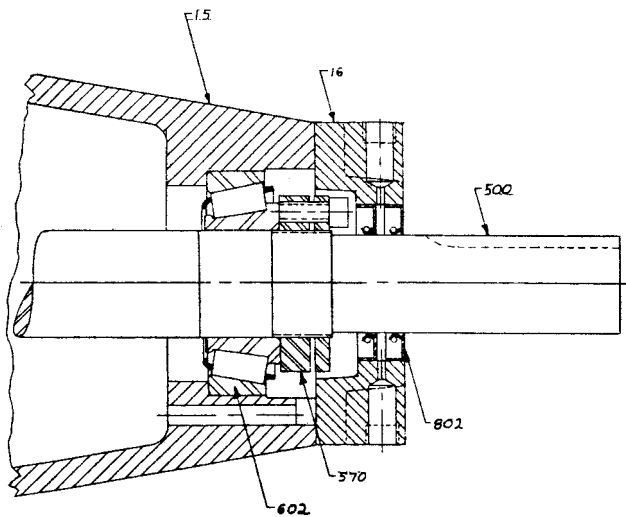

Fig. 17

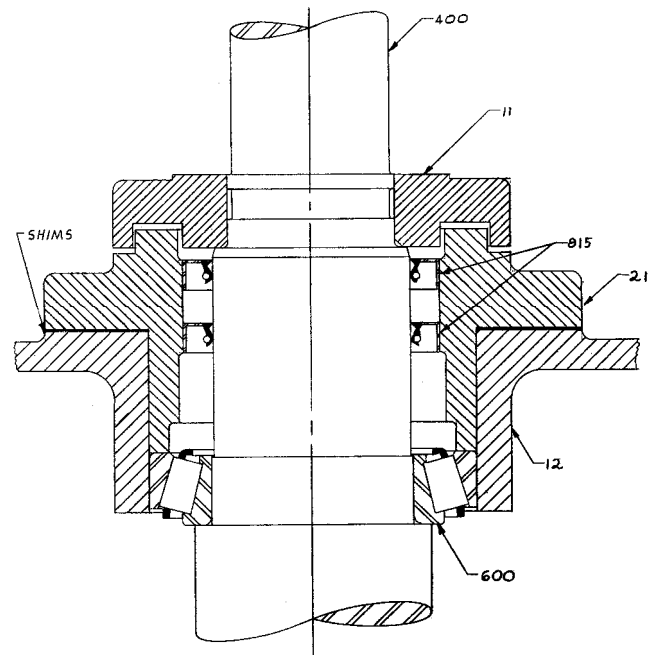
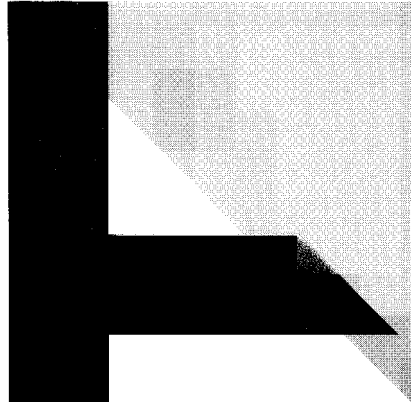
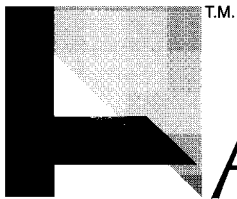

Fig. 18



Amarillo[®]
Gear
Company

T.M.



Amarillo[®] Gear Company

Post Office Box 1789 • Amarillo, Texas 79105 • 2401 Sundown Lane (79118) 806-622-1273 • FAX 806-622-3258

www.amarillogear.com

email: info@amarillogear.com

© AGC 2002